



Satellite Learning Sheet

Monday, May 4th

Student's Name: _____

Student Score	
3	All work was completed and initiated.
2	Some work missing or incomplete.
1	SLS work not completed.

MEMO	Newsletter: Please take a moment to read through the May Newsletter in your child's binder!
Parent Initials	MEMORY VERSE / BIBLE
	<p>Practice the Weekly Verse: Genesis 1:30 - "Also, to every beast of the earth, to every bird of the air, and to everything that creeps on the earth, in which there is life, I have given every green herb for food"; and it was so."</p> <p>Chapel Questions: How does this verse connect to what we learned in verses 28-29? Why do you think God chose to give animals plants for food at this point in creation?</p>
	READING / LANGUAGE ARTS / WRITING
	<p>Mysterious Benedict Society: Chapter 28 - Practice Makes Perfect</p> <ul style="list-style-type: none"> - Read the entire chapter (Pages 345 - 350) - Answer the Comprehension Questions <p>Spelling: Find your new spelling list in your binder.</p> <ul style="list-style-type: none"> - Have a parent or older sibling give you a spelling "pretest". - After the pretest, circle the words you got wrong and write them correctly 3 times next to the misspelled word.
	MATH
	<p>Additive Volume of Composite Prisms:</p> <ul style="list-style-type: none"> - Find the volume of the composite prisms by decomposing them into two separate prisms. - Find the volume of each prism and then add the volumes together to get the total volume. <p>*Make sure to do BOTH sides*</p>
	SOCIAL STUDIES
	<p>Indentured Servant Journal Entry:</p> <ul style="list-style-type: none"> - See the back of the SLS for detailed instructions
	SCIENCE
	<p>Create a Planet: In Google Classroom</p> <ul style="list-style-type: none"> - Finish completing Page 5 - Weather and Page 6 - Space Collection (Make sure you have completed the first 6 pages of the project).

Parent Comments (questions/concerns):

Create Your Own Indentured Servant Journal Entry

What is an Indentured Servant?

A long time ago, many people couldn't afford to travel to America. Instead of paying with money, they agreed to work for a certain number of years (usually 4–7 years) without pay to someone who paid for their trip. This was called indentured servitude. After they finished their work, they were set free and could start a new life.

Your Assignment:

Imagine you are living in Europe in the 1600s or early 1700s. You have decided to leave your home and travel to America as an indentured servant. Write a journal entry where you explain:

- Why you decided to leave your home (choose a reason from the list below or make your own).
- The hardship you or your family faced that made you desperate enough to become a servant.
- The terms of your contract (How many years you agreed to work? What kind of work will you do?)
- Your feelings about starting this new journey. Share your emotions and hopes.

Possible Reasons You Might Choose (or create your own!):

- There are too many people in your town, and no jobs are available.
- Your family cannot pay off debts and could go to jail.
- You want adventure and/or a better future in America.
- Your family was forced off your land and has nowhere to live.
- You are escaping from war, famine, or illness in your country.

Possible Jobs You Might Do as a Servant (choose or invent one!):

- Working on a cotton farm
- Learning a craft like blacksmithing, carpentry, or shoemaking
- Cooking, cleaning, or taking care of children in a household
- Helping on a ship or working at the docks
- Building houses or roads

Be creative and really put yourself into the shoes of someone from long ago!

1. What predicament do the children find themselves in at the beginning of the chapter?

2. How does Kate solve the problem with the tools from her bucket?

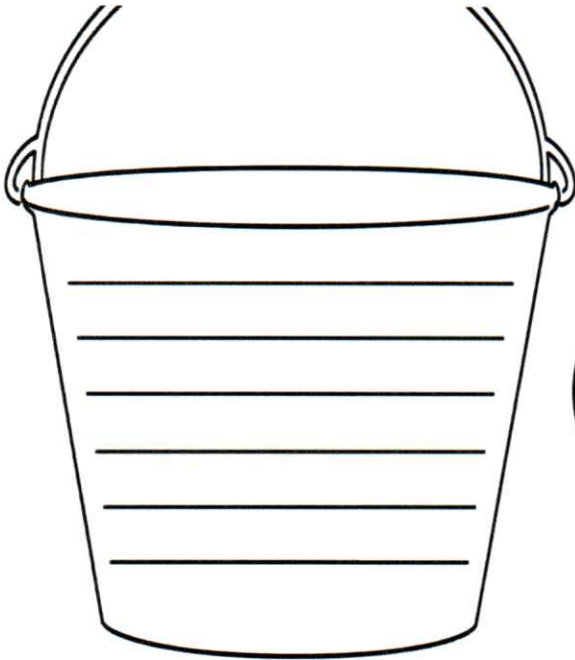

3. What is Mr. Curtain's master plan?

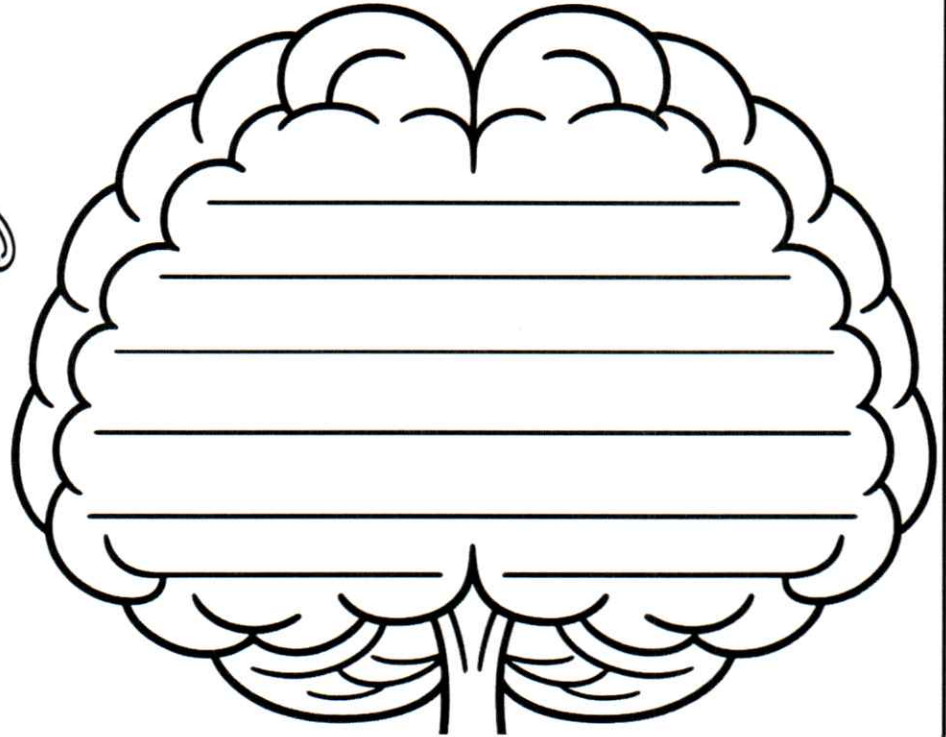

3. Mr. Curtain is planning to use fear and false peace to execute his plan. Where are some places people go to find false peace instead of turning to God's Word when they are afraid?

4. What does SAD stand for? _____

5. Make a prediction: How do you think Reynie and the others will stop Mr. Curtain's evil plan?

Name: _____



Additive Volume of Rectangular Prisms

Directions: Find the volume of each individual rectangular prism. Then find the total volume of the composite prism..

1.

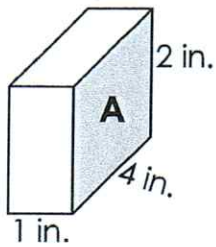

Volume of

Prism A = _____

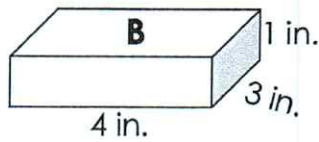

Volume of

Prism B = _____

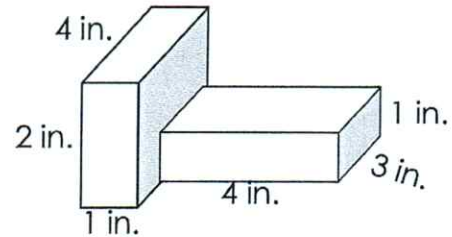

Total Volume = _____

2.

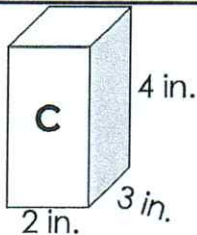

Volume of

Prism C = _____

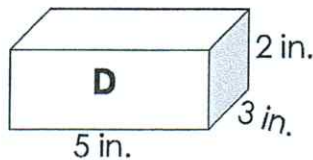

Volume of

Prism D = _____

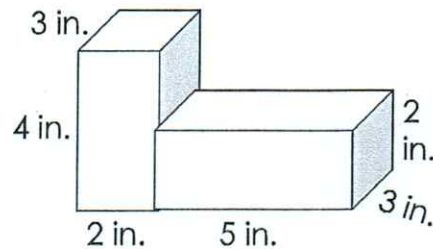

Total Volume = _____

3.

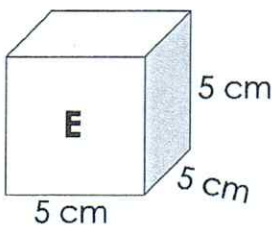

Volume of

Prism E = _____

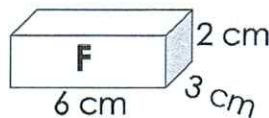

Volume of

Prism F = _____

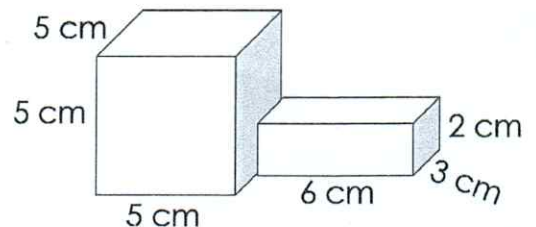

Total Volume = _____

4.

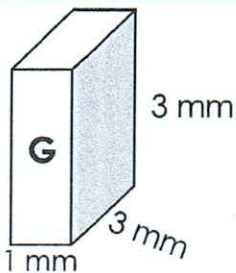

Volume of

Prism G = _____

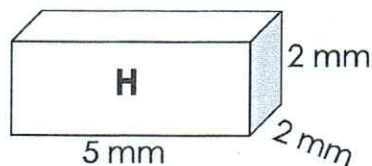

Volume of

Prism H = _____

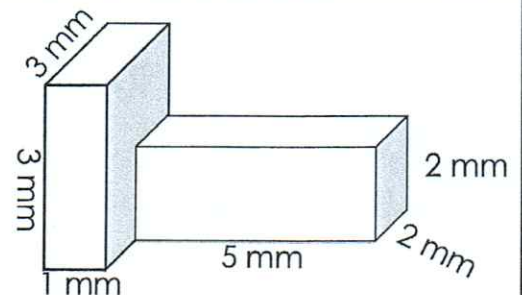

Total Volume = _____

Name: _____



Additive Volume of Composite Prisms

Directions: Find the total volume of each composite prism.

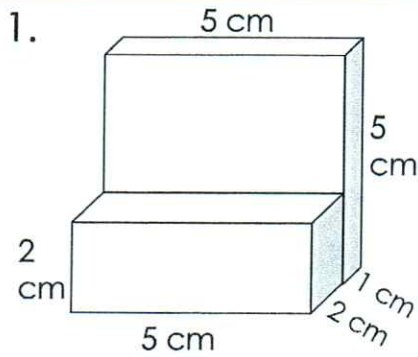

Volume = _____

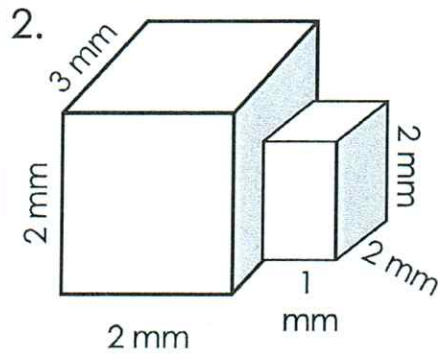

Volume = _____

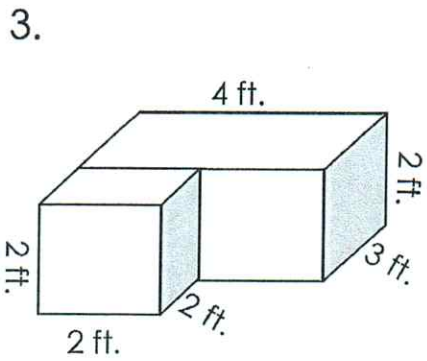

Volume = _____

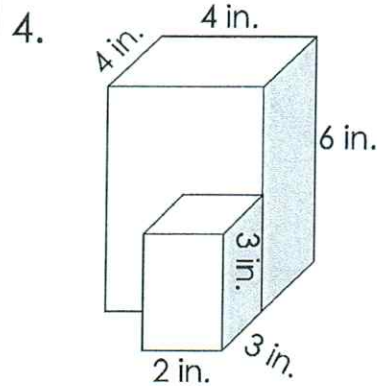

Volume = _____

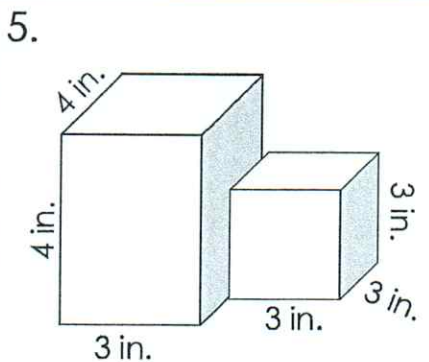

Volume = _____

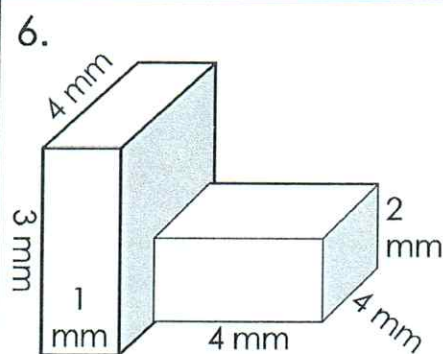

Volume = _____

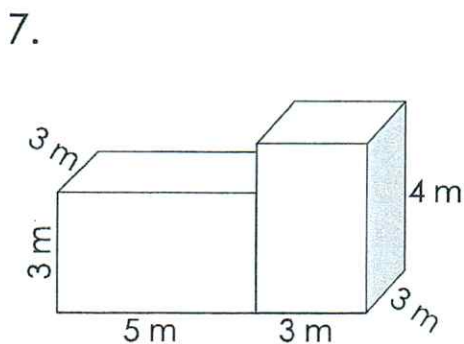

Volume = _____

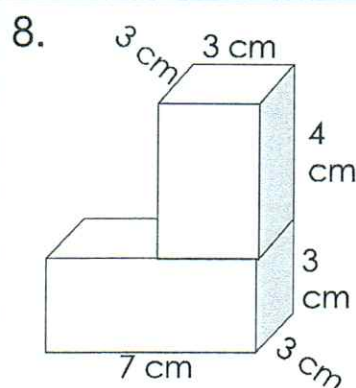

Volume = _____

Orange

5/4/26

Spelling Words

Long I - Homophones

Generalization: Homophones are words that sound the same but are spelled differently. To spell homophones correctly, students need to connect a word's meaning to its spelling pattern.

Long I

write

right

side

sighed

mite

might

Short I

billed

build

missed

mist

Challenge Word: hymn

Green
5/4/26

Spelling Words

Soft C and G

Generalization: The soft sounds of g /j/ and c /s/ are heard before e, i, and y. However, there are some exceptions, such as in *get*, *give*, and *gift*.

Soft C

cement

circle

cyclist

cider

cereal

cellar

Soft G

gymnast

giraffe

genius

gesture

giant

gentle

Challenge Word: uncivilized

Spelling Words

Prefix Assimilation - in/im/il/ir

Generalization: The spelling of the prefix in- may change to im-, il-, or -ir, depending on the first letter of the base. The meaning of the prefix, however, does not change.

in-

incorrect

inescapable

injustice

im-

immoral

immature

immobile

il-

illegal

illiterate

illogical

ir-

irrational

irresponsible

irregular

Challenge Word: illegible